

TOUR LINES

- The Program Chairs may plan only academic related tours as and when required with small groups attaching adequate or proportionate male and female faculty members.
- The Division Chair/Program Chair approving the Industrial Visit/Field Trip/Outbound Training etc., shall ensure and endorse that the faculty members attached to the tour submit an undertaking stating that the tour is arranged only for Industrial Visit connected to academics, and students will not be taken to **mountain areas, rivers, canals, beaches, water parks, reservoirs, forest areas etc.**; and, they are personally liable and answerable for any such untoward incident taking place during the tour.
- Places with potential hazards, such as political unrest, negligent security, disease outbreaks, threats of earthquake or frequent occurrence of Cyclone and flood, should be avoided.
- If the mode of transport is by bus, overnight travel is strictly not permitted. Any travel requiring more than 24 hours should not be by road (Preferable mode of Transport is Train).
- Faculty/staff arranged students' un-official tours shall be treated as violation of College Rules and the individuals organizing or arranging to organize such tours shall be subjected to appropriate disciplinary action.
- The capability of the participants to take part meaningfully in the activity must be taken into consideration when deciding the destination, itinerary and duration of the tour.
- The detailed tour schedule shall be submitted well in advance mentioning the date, time and place of departure and arrival, mode of travel (Bus/Train/Air/Ship/Other Modes), outstation accommodation arrangement details, list of important telephone numbers and addresses of the locations where the team is visiting including the phone-fax numbers of the hotel and local transport details.
- **If Travel by outside bus, FC copy of the bus should be produced with request form.**
- **Each study tour should maintain student faculty ratio of 15: 1.**

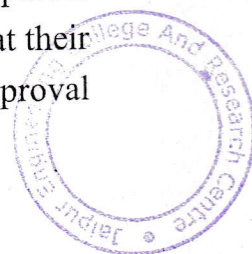

- **Lady faculty member should accompany girl students (It is applicable even if only one girl student is going for a trip)**
- The Accompanying faculties should submit the undertaking letter
- All students should get approval from their Proctor/Faculty Advisor and parents.
- The faculty members accompanying the group may be mix of multiple languages talented in order to manage tour affairs confidently and successfully.
- Faculty should authorize the complete schedule
- Club coordinator should accompany in case of representing any club
- List of students – with details (Male / female) to be submitted.
- At least one faculty member (either male or female) of the group needs to be fully acquainted with the touring stations so that they can guide and instruct students in an appropriate way accordingly to see that the students are not getting into any unforeseen incident or accident. Information relevant to the itinerary, such as the addresses and telephone numbers of the lodging places, location of the local police stations, hospitals, clinics or first-aid units as well as the emergency call numbers en route, should be collected. Such information should be given to the parents and the responsible person in the school before the trip for emergency needs.
- It is preferable to arrange two students (of same gender) or more to live in a room when allocating accommodation. This will facilitate provision of support to fellow members. Once the arrangement for accommodation is finalized, no student should be allowed to make any change without a proper reason so as to avoid causing confusion.
- No student shall be compelled to participate or to contribute money for any kind of tour just for the sake of fund management during the tour. In case of any such compulsion, the student(s) can report to the Safety Committee.
- The parents/guardians of the students (those who are participate in the tour) may be asked to submit an undertaking (by mail or fax or SMS) stating that the parent is permitting their ward to participate in the tour with their knowledge and at their own risk. Students if they are hostellers, they should get special leave approval from their respective Hostel authorities.



- Exit and Entry should be at JECRC (Faculty and Students joining the group from their hometowns and leaving to their hometowns after the tour is not permitted under any circumstances)
- Before leaving for Industrial Visit concerned faculty organizer shall arrange to procure adequate and proper FIRST AID KIT if necessary. The faculty members shall accompany the students throughout the tour/trip and shall stay along with the students.
- No faculty member attached to the tour shall alternate or replace other faculty/staff member on his/her behalf without prior proper approval of the Director.
- It is advisable that at least one of the faculty or participants should know first aid.
- Students should be reminded of the need to follow the Faculty instructions and observe all the safety regulations throughout the trip.
- After checking in a local hotel, the students should first find out where the "fire escape" is. They should also acquaint themselves with the exit direction, the escape route and the place of assembly in case of emergency.
- Faculty accompanying should pay attention to the weather forecasts and news broadcasts of the place of visit. If there is any change in weather or other conditions, a contingency plan should be worked out as soon as possible.
- The faculty should have full knowledge of the health condition of each participant in order to determine whether specific participant(s) should not be allowed to take part in the activities of the day. He/she should take timely and appropriate action having regard to the circumstances of individual cases.
- The faculty should also arrange for any sick member to see the doctor immediately and to take effective preventive measures according to the doctor's advice. If necessary, the faculty should inform the parents and the school regarding the students' health conditions as soon as possible.
- The faculty should bring along with him/her the necessary safety equipment for the tour, for example, a first aid box, communications equipment (mobile phones), torches, etc.
- The faculty should monitor the speed of the vehicle (bus) in which they are traveling to ensure it is within safety limits. He/she should remind the driver or

the reception personnel of the importance of road safety when necessary.

- After returning from the tour, the concerned faculty team shall submit a **INDUSTRIAL TOUR REPORT** to the BHRAMANN Team.

1. Mr. Rahul Kumar Malee (EE) 

2. Mr. Shailendra Shrivastava (EE) 

5 Ashish SHARMA 

3. Ms. Neha Agarwal (EE) 

4. Mr. Anoop Kumar Mehta (CSE) 

**Above signed faculty members are responsible for all above mentioned guidelines to be followed during this Industrial Visit.

BHRAMANN TEAM

1. Mr. Naresh Kumar (ECE)

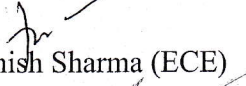
2. Mr. Ashish Sharma (ECE) 

3. Ms. Shweta Sharda (ECE) 

4. Ms. Aapurva Kaul (ECE) 

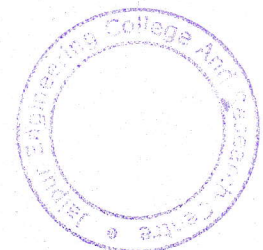

Jaipur- Mumbai -lonavala With AdlabsImagica Water Park

- **Duration** 5Nights / 6Days
- **Destination:** Mumbai –Imagica Water Park-Lonavala
- **Cost Per head** 7800/- Per Student
- **Cost Per Head** 8000/- (If Required 2*2 Bus)

Day 1 Jaipur–Mumbai

Arrive at Jaipur Railway Station At 1 PM, Board In Train at (2 Pm JpBct Sup.) & O/n Journey for Mumbai (Dinner)

Day2 Mumbai –Imagica Water Park-Lonavala

Arrive Mumbai railway station 7.30 Am, Board in bus & Proceed AdlabsImagica Water Park Enjoy here world famous water rides till evening after this proceed for Lonavala check inn hotel after dinner o/n stay at hotel (Breakfast/Lunch/Dinner)

Day3.Lonavala

Morning after breakfast & lunch enjoy sightseeing of lonavala like –Tiger leap , Bushy dam, lonavala lake , Curla caves, Sunset point etc evening back to hotel enjoy Dj party after dinner o/n stay at hotel. (Breakfast/Lunch/Dinner)

Day 4Lonavala- Mumbai

Morning after breakfast check out from hotel & proceed for Mumbai on arrival check in hotel after lunch enjoy sightseeing of Mumbai like- Gateway of India, Nariman Point, Mahalaxmi Temple, Hazi Ali, JuhuChaupati etc evening back to hotel after dinner o/n stay at hotel.(Breakfast/Lunch/Dinner)

Day 5 Mumbai -Jaipur

Morning after breakfast checkout from hotel & proceed for Industrial visit after this proceed for Mumbai Railway station board in train (6.50 Pm MmctJp SupExp) & o/n journey for Jaipur.(Breakfast/Lunch/Dinner)

Day 6Jaipur

Reach Jaipur Railway Station at 12.45 Pm. (Breakfast)

TOUR END WITH HAPPY MEMORIES

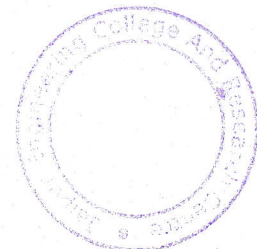

Industry Any 1-2 (According to Subject & Matter of Permission.)

- Navbharat Electrical Industry
- Excel Electric Industries
- Lumina Electrical Industries PVT.LTD
- Bushy Dam
- Worli Sea link.
- STPI
- C-Dacor Similar

Inclusion

1. Accommodation at 4 sharing In 3 star
2. Transport 3*2(Non AC)
3. All major Sightseeing
4. Return train tickets (sl class)
5. Entry ticket of Imagica water park
6. 1 Dj Party
7. Mineral water 1 bottle per day
8. Train meal
9. Morning Tea- Coffee
10. Travel Insurance till 1 lakh
11. Buffet Breakfast, lunch & dinner at hotel
12. First Aid Kit
13. All monument Entry
14. Teacher comp 15:1
15. Toll Tax, Parking ,Driver Allowance

Exclusion

1. 5 % Gst
2. Any porter charges
3. Any personal nature expenditure
4. Anything not mentioned under cost included items
5. Any uses in the hotel like telephone, laundry personal order etc.
6. Any damage/destroy in the hotel room by clients, will be directly chargeable to clients
7. Horse riding / Water Sports



Payment terms:

1. 50% of the complete package amount (pertaining to the minimum guarantee of student count) at the time of booking of the package;
2. 40% of the rest amount to be paid 15 days before the date of departure
3. 10% of the rest amount to be paid within 7 days of completion of tour.

Cancellation Charges/Policy:

1. Cancellation before 15 days before departure date a cancellation charge of 25% of the total tour package amount.
2. Cancellation before 3 days and up to 15 days before departure date a cancellation charge of 50% of the total package amount.
3. No show or cancellation up to 3 days before departure date a cancellation charge of 100% of the total package amount.

TERMS AND CONDITIONS:

1. Rates mentioned in this contract are applicable only for this Conference/Leisure Trip/Offsite/Training Program/Event to be held on the date mentioned in this proposal.
2. Early check-in and late check-out will be charged additionally as per subject to the hotel policies.
3. If there be any reduction in the minimum guaranteed number of pax, Travel12go. Travel12go will charge on the minimum guaranteed number of pax as per the contract and if the number of pax increases, then the billing will be done on the actual number of pax.
4. We would require the signed copy of the contract along with advance payment on the day of signing this contact.
5. We would require the request for additional services if there any, in writing before 10 days from the departure date of Conference/Leisure Trip/Offsite/Training Program/Event and it will be charged extra.
6. All Government policies/regulations prevalent during the time of signing the contract will apply. Travel12go will not be held responsible for any subsequent changes in the government policies, rules and/or regulations. Although no effort will be spared to provide the requested services, travel12go only as agent for Transportation Companies, Hotels, Car operators, Raft operators, DJs,
7. Travel12go reserves the right without being liable for any loss or damage, to change the itinerary with or without notice and at its sole discretion, if found to be in the best interest of all concerned.
8. All disputes will be settled subject to the jurisdiction of rajasthan Courts as per the Laws Prevalent in India at the time of signing the contract.
9. Stage makers, dancer, celebrities and all other contractors, and will therefore have to disclaim responsibility for:
 - i. Any loss, damage or miss-happening what so ever to any person, luggage or property during the entire journey or at the place of stay or during sightseeing or any adventure or other activity.
 - ii. Delay or alteration in programs or expenses due to unforeseen circumstances.
 - iii. Strikes, vehicle breakdown, sickness, or civil unrest and other problems beyond the control of the company

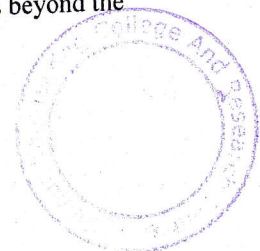



Jaipur Engineering College and Research Centre

Department of Electrical Engineering

NOTE SHEET

From: HoD EE

To: Principal JECRC Jaipur

Noting Reference No: JECRC/EE/2018-19/odd/28

Date:20-09-2018

The Department of Electrical Engineering is organizing a five day Industrial Tour at Mumbai during the first week of October 2018. This Industrial tour is organizing for the students of 2nd and 3rd year Electrical Engineering branch.

This is for your kind information to give the permission for industrial tour.

Faculty Coordinator

Shailendra Shrivastava

(Assistant Professor)

Rahul Kumar Maloo

(Assistant Professor)

HOD

Department of EE

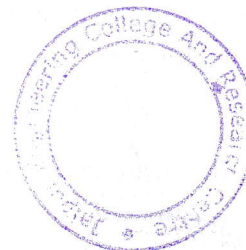



JAIPUR ENGINEERING COLLEGE
AND RESEARCH CENTRE

Ref JECRC/2018-19/103

02/10/18

To

The Associate Director
BTDG
BARC, Mumbai.

SUB: Permission for Industrial Visit – B.Tech Students

Sir/Madam,

As you may be aware, Jaipur Engineering College & Research Centre, Jaipur is one of the most reputed engineering institutions in Rajasthan and known for its excellent record in academics and co-curricular activities. The college offers bachelors degree course in ECE, EE, CSE, IT, ME and Civil branches. The state-of-art facilities and competent faculty provide an excellent climate for the all-round development of students.

As a part of the curriculum, the students are required to undertake industrial visits to few industries of repute. It will be fruitful for the students with academic background to have a glimpse of the industry in order to have a better knowledge of practical applications of theory. In the above background we would like to send a batch of about 56 students of Electrical Engineering and Computer science Engineering Branch of 2nd and 3rd year accompanied by 5 faculty members to visit your esteemed industry preferably on 15th October 2018.

We kindly request you to accord the necessary permission for the above visit and arrange for guiding the students. We assure you that our students will follow the rules and regulations that are prescribed by your company for the visitors and will in no way disturb the functioning of the company during their visit. We shall be grateful for a favorable response.

Thanking You,

Yours faithfully,

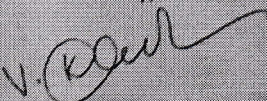
Dr. V.K. Chandna
Principal

Jaipur Engineering College and Research Centre

Approved by AICTE & Affiliated to RTU

JECRC Campus, Shri Ram Ki Nangal,

Via Sitapura Bypass Road, Tonk Road, Jaipur 302 022



JECRC Foundation

www.jecrcfoundation.com

Request for Industrial visit

8 messages

BHRAMANN BHRAMANN <bhramann@jecrc.ac.in>

Tue, Oct 2, 2018 at 12:00 PM

To: rkraj@barc.gov.in, rib@barc.gov.in

Cc: vishnu@barc.gov.in

Respected Sir,

Please find the attachment in regards of Industrial visit. awaiting for your response to execute further process for the same.

--

Regards

BHRAMANN Team

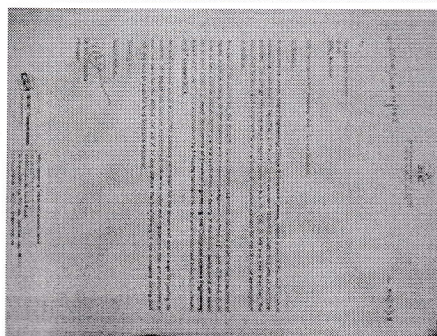
**industrial visit letter.jpg**
1195K

BHRAMANN BHRAMANN <bhramann@jecrc.ac.in>

Tue, Oct 2, 2018 at 12:02 PM

To: Naveen Sharma <travel12go@gmail.com>

[Quoted text hidden]

--

Regards

BHRAMANN Team

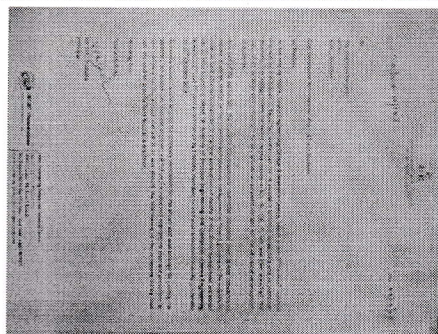
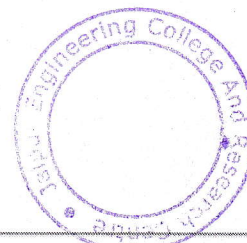
**industrial visit letter.jpg**
1195K

vishnu@barc.gov.in <vishnu@barc.gov.in>

Thu, Oct 11, 2018 at 11:50 AM

To: BHRAMANN BHRAMANN <bhramann@jecrc.ac.in>

[Quoted text hidden]

Dear Dr. Chandna and Bhramann team of JECRC,

Head APPD has given approval for this visit at EBC Kharghar on 15th October, Monday.

I am giving this confirmation on his behalf.

Vishnu Kumar Sharma
Scientific Officer (E)
APPD, BARC

BHRAMANN BHRAMANN <bhramann@jecrc.ac.in>

Thu, Oct 11, 2018 at 11:53 AM

To: "Director JECRC (Director JECRC)" <director@jecrcmail.com>, Principal JECRC <principal@jecrc.ac.in>, "principal@jecrcmail.com" <principal@jecrcmail.com>

For your kind information.

[Quoted text hidden]

--
Regards
BHRAMANN Team

BHRAMANN BHRAMANN <bhramann@jecrc.ac.in>

Thu, Oct 11, 2018 at 12:36 PM

To: Naveen Sharma <travel12go@gmail.com>

----- Forwarded message -----

From: <vishnu@barc.gov.in>

Date: Thu, Oct 11, 2018 at 11:51 AM

Subject: Re: Request for Industrial visit

To: BHRAMANN BHRAMANN <bhramann@jecrc.ac.in>

[Quoted text hidden]

--
Regards
BHRAMANN Team

BHRAMANN BHRAMANN <bhramann@jecrc.ac.in>

Thu, Oct 11, 2018 at 12:37 PM

To: Naveen Sharma <travel12go@gmail.com>

[Quoted text hidden]

--
Regards
BHRAMANN Team

BHRAMANN BHRAMANN <bhramann@jecrc.ac.in>

Tue, Oct 23, 2018 at 2:23 PM

To: Ashish Ameria <ashishameria.cse@jecrc.ac.in>

----- Forwarded message -----

From: **BHRAMANN BHRAMANN** <bhramann@jecrc.ac.in>

Date: Thu, 11 Oct 2018 at 12:37 PM

Subject: Fwd: Request for Industrial visit

To: Naveen Sharma <travel12go@gmail.com>

[Quoted text hidden]

--
Regards
BHRAMANN Team

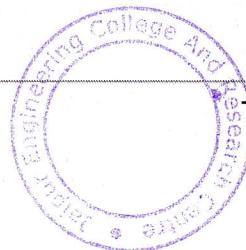

BHRAMANN BHRAMANN <bhramann@jecrc.ac.in>

Tue, Oct 23, 2018 at 2:23 PM

To: Ashish Ameria <ashishameria.cse@jecrc.ac.in>

----- Forwarded message -----

From: **BHRAMANN BHRAMANN** <bhramann@jecrc.ac.in>

Date: Tue, 2 Oct 2018 at 12:00 PM

Subject: Request for Industrial visit

To: <rkraj@barc.gov.in>, <rib@barc.gov.in>
Cc: <vishnu@barc.gov.in>

[Quoted text hidden]

--
Regards
BHRAMANN Team

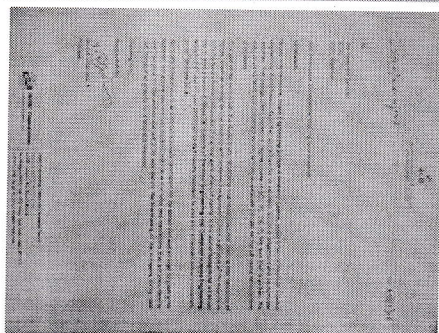

industrial visit letter.jpg
1195K



Jaipur Engineering College & Research Centre, Jaipur
DEPARTMENT OF ELECTRONICS AND COMMUNICATION

27/09/2018

NOTE SHEET

Subject: Expenditure budget for BHRAMANN'18

The expenditure budget for BHRAMANN'18 is as follows.

S. No.	Item	Budget (Rs.)
1.	Fees	8000/- per student
2.	Total Collection (till 28-09-2018)	448000/-
S. No.	Item	Expenditure (Rs.)
1.	T-Shirt	11200/-
2.	Paid in advance to Travel 1 2 Go (on 01-10-2018)	220,000/-
3.	Paid in Lonavala (on 14-10-2018)	121200/-
4.	Paid in Mumbai (on 16-10-2018)	45600/-
5.	Paid after feedback (on 22-10-2018)	50000/-
Total Rs.		448000/-

Submitted for your kind approval,

BHRAMANN Team

PRINCIPAL



Department of Electrical Engineering & Computer Science

Ambai(BARC) Industrial Trip Student List(16 to 17 october)

S.N	Name	Age	Year	Self Contact No	Email Id	Father's Name	Mother's name	Parent's contact no	Branch
1	harsh kalyani	20	3	9887986255	harsh.asdfgh@gmail.com	ashok kalyani	Chitra Kalyani	9887113913	EE
2	anmol bishnoi	20	3	9521443901	bishnoianmol10@gmail.com	ram kumar bishnoi	nirmala bishnoi		EE
3	jayesh ameta	21	3	7891030031	jayameta@gmail.com	S S ameta	sumitra ameta	9414471139	EE
4	himank chaturvedi	20	3	8104594073	harshitchaturvedi98@gmail.com	Gopal krishna chaturvedi	Sapna chaturvedi	9610266265	EE
5	himank kumawat	20	3	8852942741	himank082@gmail.com	vinod kumawat	Kamlesh Kumawat	9252604288	EE
6	kanishk agarwal	18	3	7727857575	kanishk0230@gmail.com	Girraj Prasad Gupta	hemlata Gupta	8504936271	EE
7	amit mewara	20	3	9818381102	amitmewara143@gmail.com	Om Prakash Mewara	sunita devi		EE
8	Anubhav Sharma	19	3	9982314545	786anubhavsharma@gmail.com	Ishwari Prasad Sharma	Asha Sharma	7014340854	EE
9	harshit vijay	19	3	8696456018	hvjay34@gmail.com	Rajesh vijay	anita vijay	8696456140	EE
10	Varun Joshi	21	3	9309323190	vjarunjoshi007@gmail.com	Sumil Kumar Joshi	Amita Joshi	9783957378	EE
11	neelansh mittal	19	3	9269506565	mittalneelansh981n@gmail.com	neerajan kumar jain	sweety jain	9269585292	EE
12	prajwal jain	21	3	7023636844	jain139prajwal@gmail.com	surendra kumar jain	padma jain	7737166655	EE
13	nishant jain	19	3	7737575185	nishant1999jain@gmail.com	HARISH KUMAR	rekha jain	9214987084	EE
14	vinayak dhadich	20	3	9828060965	vinayakkumardhadich@gmail.com	Dinesh sharma	manju sharma	9887607482	EE
15	Vaibhav tolambiya	20	3	8560828389	vaibhavtolambiya@gmail.com	rajesh tolambiya	taruna tolambiya	8769096701	EE
16	raj kumar	20	3	8239816341	rjpurbiyal6@gmail.com	shobalal kalal	laxmi purbia	94603	EE
17	Kartik kachhara	18	3	9461098115	kj84410@gmail.com	lalit kachhara	suman kachhara		EE
18	vishal soni	19	2nd	9521666055	vishalsoni0002@gmail.com	ganshayam soni	pushpa soni		EE
19	ravi sharma	20	2nd	9602780101	joshi.ravi9829021740@gmail.com	babulal sharma	manju sharma	98299	EE
20	yash soni	19	2nd	9079570834	yashsonibali1@gmail.com	ganshayam soni	vimla soni	96945	EE
21	vishal dewat	19	3	9785701270	vkdwat57@gmail.com	durga lal dewat	sugna devi	94626	EE
22	aditya joshi	20	2nd	7340281696	aditya27aditya@gmail.com	shailesh joshi	asha sharma	9413904807	EE
23	manoj kumar kalal	18	2 year	7023671498	mjmewara21@gmail.com	Mr. Ram Lal kalal	Miss Ram kanya	9680354978	EE
24	kunvar preet singh	19	2 year	7737746983	kunvarpreetsingh04@gmail.com	Mr. K S chadha	Miss Ramandeep ka	9610360594	EE
25	ishan bhargava	20	2	9314515485	ishanbhargava333@gmail.com	lokesh bhargav	shalini bhargav		EE
26	indraveer singh	17	2 year	9636872414	shikarindrashigh15@gmail.com	Mr. Dharamveer Singh	Miss Reeta Singh	9983045612	EE
27	rajat verma	20	3	7023456740	rajat2015verma@gmail.com	Shreeram verma	Anju Verma	9928619467	EE
28	Bharti sharma	20	2 year	8279663097	bharatiag15@gmail.com	Mr. V K Sharma	Miss Hemlata Sharma	8279663097	EE
29	akshita gaur	20	2nd year	9649264680	akshitagaur.ee21@gmail.com	vishnu kumar sharma	manju sharma	9783374523	EE
30	shaiphali jain	20	3rd	9828282121	shaiphaliainjain@gmail.com	deepak kumar jain	saroj rani jain	9414823535	EE
31	pooja goswami	21	3rd yr	7732971944	poojagoswami040@gmail.com	Doulat Goswami	meena goswami	7976126748	EE
32	neha shaktawat	20	3rd yr	7300329897	nehha08shaktawat@gmail.com	gajendra singh	indu shaktawat	9460677897	EE
33	Isha Jain	20	3rd year	7297867723	ishajain140@gmail.com	Jitendra jain	Neera Jain	8829064140	EE
34	kanika khandelwal	20	3rd year	7014383630	kanikakhandelwal5589@gmail.com	rajendra prasad gupta	sumita gupta	9982062365	EE
35	Rishabh Jain	20	2nd	9571222502	jain19950@gmail.com	chandra prakash jain	anita jain	6350321797	EE
36	himanshu jain	20	3rd year	9660351278	himanshu.asdfgh@gmail.com	Mr Sunil Kumar jain	sadhana jain	7727030987	EE
37	vaibhav gupta	20	3rd year	7734820627	vaibhavgupta@gmail.com	Rajendra Gupta	Sunita Gupta		EE

38	Usha meena	20	2nd year	8561075301	ushameena54093@gmail.com	Prakash Chand Meena	Motya Meena	9887545833	EE
39	nikita goyal	18	2nd(EE)	8947958	nikitagoyal.ee.21@jecrc.ac.in	ashok goyal	seema goyal	9785589432	EE
40	Shivani Mahajan	19	2nd(EE)	9785128877	shivanimahajan037@gmail.com	deendayal gupta	sunita gupta	9414527245	EE
41	Tiksha Kumari	18	2nd(EE)	9664060087	fikshakumari2000@gmail.com	Bhagwan Shahay	dhanlaxmi	9024622555	EE
42	Sneha Jindal	19	2nd	9057085788	snehajindal2001@gmail.com	santosh agarwal	radha devi	7378123412	EE
43	Himani Jharotiya	21	3rd yr(E)	9587199808	himanijharotiya@gmail.com	Bairanj lal Jharotiya	Indra Jharotiya	8696548411	EE
44	Devashish Sharma	20	3rd year	8003144526	Sharma.devashish21@gmail.com	purshottam sharma	asha sharma		EE
45	Devesh Gupta	20	3rd year	9667700543	deveshgupta.ce20@jecrc.ac.in	Dinesh Gupta	Jaimala Gupta	7073685262	EE
46	Divyansh Sharma	20	3rd	7976296019	dsharma051998@gmail.com	Mr. Ravindra Sharma	Mrs. Namrata Sharm	9928086788	CSE
47	Nishant Ramawat	20	3rd	8385858404	nishusbnkn@gmail.com	Mr. Hari Prasad Ramawat	Mrs. Neetu Ramawa	9782424141	CSE
48	Namandeep Singh	19	3rd	8290601980	namandeepsingh208@gmail.com	Mr. Hardeep Singh	Mrs. Navjeet Kaur	9336119134	CSE
49	Shashank Middha	20	3rd	9783214789	shshankmiddha@gmail.com	Mr. Hansraj Middha	Mrs. Gulshan Middh	9983464645	CSE
50	Sarthak Nazkani	20	3rd	7665355074	sarthaknazkani47@gmail.com	Mr. R.K. Nazkani	Mrs. Meena Nazkani	9001197750	CSE
51	Shreya Singhal	19	3rd	9950353798	shreyasinghal70219@gmail.com	Mr. Shantanu Singhal	Mrs. Madhu Agarwal	9413359079	CSE
52	Shrikrishan Khandelwal	21	3rd	9529116305	shrikrishan.khandelwal@gmail.com	Mr. Ghanshyam Das	Mrs. Brijlata	9828127545	CSE
53	Soumil Khandelwal	19	3rd	7976686532	soumil.k@gmail.com	Mr. Anil Khandelwal	Mrs. Sheela Khande	9414496824	CSE
54	Utkarsh Jain	21	3rd	9610137086	jainutkarsh567@gmail.com	Mr. Vimal Kumar Jain	Mrs. Rita Jain	7597284468	CSE
55	Utsav Sharma	21	3rd	8005529829	utsavsharma619@gmail.com	Mr. Kapil Sharma	Mrs. Taruna Sharma	9414309614	CSE
56	Yukti Goswami	20	3rd	7231801118	yuktig.jaipur@gmail.com	Dr. Ananya Goswami	Mrs. Chhaya Gupta	9414519952	CSE
Faculty members details									
S.N	NAME	AGE	GENDE	BRANCH	FATHER'S NAME				
1	Ashish Sharma	32	Male	ECE	Phani Bhushan Sharma				
2	Anoop Kumar Mehta	26	Male	CSE	Prakash Chandra Mehta				
3	Shailendra Srivastava	38	Male	EE	P.N.Srivastava				
4	Rahul Kumar Malee	26	Male	EE	Kirodeelal Malee				
5	Neha Agrawal	27	Female	EE	Jagajcewan Agrawal				





JAIPUR ENGINEERING COLLEGE
AND RESEARCH CENTRE

Ref: _____

Date: 11-10-2018

UNDERTAKING LETTER - FACULTY

We here-by undertake that the Industrial Visit to **Mumbai-Lonavala** from **12th October 2018** to **17th October 2018** is purely academic related and at any case.

We shall undertake full responsibility of the student's actions and behavior at all times during the course of Industrial Visit. We further undertake not to breach the safety guidelines of the JECRC College at any cost.

S.No.	Employment Id.	Name	Signature
1.	EE0062	RAHUL KUMAR MALEE	
2.	CS0090	Anoop Kumar Mehta	
3.	EC0111	ASHISH SHARMA	
4.	EE0066	Shailendra Shrivastava	
5.	EE0059	Neha Agrawal	



JECRC Foundation
www.jecrcfoundation.com

Jaipur Engineering College and Research Centre

Approved by AICTE & Affiliated to RTU

JECRC Campus, Shri Ram Ki Nangal,

Via Sitapura RIICO, Opp. EPIP Gate, Tonk Road, Jaipur 302 022

t: 0141 2770120, 2770232 e: info@jecrcmail.com

Undertaking for Industrial Tour

Mr. Gopal Krishan Chaturvedi & Mrs. Sapna Chaturvedi parents of Himank Chaturvedi bearing Register number 890368 studying in III/V -Semester, Department of Electrical Engineering in Jaipur Engineering College and Research Centre, Jaipur here with voluntarily submitting the undertaking. We, the undersigned parents/guardian are aware that, our son/daughter is participating in the industrial tour organized by the Institute scheduled during 12/ 10/2018 to 17/10/2018 with our full acceptance and will be bearing all the expenditure incurred for the Industrial tour towards travel and other expenses from our end.

We shall ensure that our son/daughter shall abide by the college terms and conditions for industrial tour. We, hereby declare and confirm that the college shall not be held responsible in the event of any misfortune or accidents and/or personal injuries whether fatal or otherwise involving our son/daughter. We shall undertake full responsibility of all the consequences should any other person or body suffer such accidents and/or personal injuries and/or damage to property as a result of our son/daughter negligent act during the period of industrial tour.

We further confirm that the college shall not be held responsible for our son/daughter misconduct or wrongdoing at all times during the period of industrial tour and shall obey the instructions of the faculty members who are accompanying during the industrial tour.

Yours sincerely,

 Signature of the student

Contact Phone No: 8104594073

Name of the Father: Gopal Krishan Chaturvedi

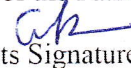
(Parents Signature)  Sapna

Contact Phone No: 9610266265

Name of the Mother: Sapna Chaturvedi

Name of the Guardian: Gopal Krishan Chaturvedi

Contact Address: Mansarovar, Jaipur

Contact Phone No: 9587548452

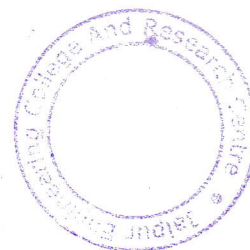

Undertaking for Industrial Tour

Mr. Ashok Kalyani & Mrs. Chitra Kalyani parents of Harsh Kalyani bearing Register number JECRC / 10 / 300364 studying in III/V -Semester, Department of Electrical in Jaipur Engineering College and Research Centre, Jaipur here with voluntarily submitting the undertaking. We, the undersigned parents/guardian are aware that, our son/daughter is participating in the industrial tour organized by the Institute scheduled during 12/ 10/2018 to 17/10/2018 with our full acceptance and will be bearing all the expenditure incurred for the Industrial tour towards travel and other expenses from our end.

We shall ensure that our son/daughter shall abide by the college terms and conditions for industrial tour. We, hereby declare and confirm that the college shall not be held responsible in the event of any misfortune or accidents and/or personal injuries whether fatal or otherwise involving our son/daughter. We shall undertake full responsibility of all the consequences should any other person or body suffer such accidents and/or personal injuries and/or damage to property as a result of our son/daughter negligent act during the period of industrial tour.

We further confirm that the college shall not be held responsible for our son/daughter misconduct or wrongdoing at all times during the period of industrial tour and shall obey the instructions of the faculty members who are accompanying during the industrial tour.

Yours sincerely,

H. Kalyani Signature of the student

Contact Phone No: 9887986255

Name of the Father: Ashok Kalyani

(Parents Signature) Ashok Kalyani

Contact Phone No: 9414234517, 7568 464117

Name of the Mother: Chitra Kalyani

Name of the Guardian: _____

Contact Address: Fatehpura, Udaipur

Contact Phone No: _____

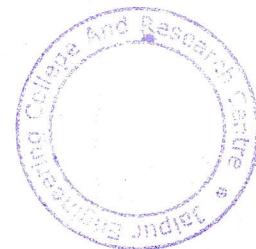

Undertaking for Industrial Tour

Mr. Ram Kumar Bishnoi & Mrs. Nirmala parents of Amul Bishnoi bearing Register number JCRC/100/500338 studying in III/V-Semester, Department of Electrical Engineering in Jaipur Engineering College and Research Centre, Jaipur here with voluntarily submitting the undertaking. We, the undersigned parents/guardian are aware that, our son/daughter is participating in the industrial tour organized by the Institute scheduled during 12/10/2018 to 17/10/2018 with our full acceptance and will be bearing all the expenditure incurred for the Industrial tour towards travel and other expenses from our end.

We shall ensure that our son/daughter shall abide by the college terms and conditions for industrial tour. We, hereby declare and confirm that the college shall not be held responsible in the event of any misfortune or accidents and/or personal injuries whether fatal or otherwise involving our son/daughter. We shall undertake full responsibility of all the consequences should any other person or body suffer such accidents and/or personal injuries and/or damage to property as a result of our son/daughter negligent act during the period of industrial tour.

We further confirm that the college shall not be held responsible for our son/daughter misconduct or wrongdoing at all times during the period of industrial tour and shall obey the instructions of the faculty members who are accompanying during the industrial tour.

Yours sincerely,

Amul Bishnoi Signature of the student

Contact Phone No: 9521443901

Name of the Father: Ram Kumar Bishnoi

(Parents Signature)

Contact Phone No: 9614997689

Name of the Mother: Nirmala

Name of the Guardian: Amul

Contact Address: 3/376 Old RHB colony Sec 13, Jaipur - 335804

Contact Phone No: 9614997689



Undertaking for Industrial Tour

Mr. S.S. Ameta & Mrs SUMITRA AMETA parents of
JAYESH AMETA bearing Register number _____
studying in III/V-Semester, Department of ELECTRICAL ENGINEERING in Jaipur
Engineering College and Research Centre, Jaipur here with voluntarily submitting the under
taking. We, the undersigned parents/guardian are aware that, our son/daughter is participating in
the industrial tour organized by the Institute scheduled during 12/ 10/2018 to 17/10/2018 with
our full acceptance and will be bearing all the expenditure incurred for the Industrial tour
towards travel and other expenses from our end.

We shall ensure that our son/daughter shall abide by the college terms and conditions for
industrial tour. We, hereby declare and confirm that the college shall not be held responsible in
the event of any misfortune or accidents and/or personal injuries whether fatal or otherwise
involving our son/daughter. We shall undertake full responsibility of all the consequences should
any other person or body suffer such accidents and/or personal injuries and/or damage to
property as a result of our son/daughter negligent act during the period of industrial tour.

We further confirm that the college shall not be held responsible for our son/daughter
misconduct or wrongdoing at all times during the period of industrial tour and shall obey the
instructions of the faculty members who are accompanying during the industrial tour.

Yours sincerely,

Jayesh Signature of the student
Contact Phone No: 7891030031

Name of the Father: S.S. Ameta

(Parents Signature)

Contact Phone No: 9929595239

Name of the Mother: SUMITRA AMETA

Sumitra

Name of the Guardian: S.S. Ameta

Contact Address: Pratapnagar, Udaipur

Contact Phone No: 9414471139



Undertaking for Industrial Tour

Mr. Hari Prasad Ramawat & Mrs Neetu Ramawat parents of Nishant Ramawat bearing Register number 16FJCCS 111 studying in III/V -Semester, Department of COMPUTER SCIENCE in Jaipur Engineering College and Research Centre, Jaipur here with voluntarily submitting the undertaking. We, the undersigned parents/guardian are aware that, our son/daughter is participating in the industrial tour organized by the Institute scheduled during 12/ 10/2018 to 17/10/2018 with our full acceptance and will be bearing all the expenditure incurred for the Industrial tour towards travel and other expenses from our end.

We shall ensure that our son/daughter shall abide by the college terms and conditions for industrial tour. We, hereby declare and confirm that the college shall not be held responsible in the event of any misfortune or accidents and/or personal injuries whether fatal or otherwise involving our son/daughter. We shall undertake full responsibility of all the consequences should any other person or body suffer such accidents and/or personal injuries and/or damage to property as a result of our son/daughter negligent act during the period of industrial tour.

We further confirm that the college shall not be held responsible for our son/daughter misconduct or wrongdoing at all times during the period of industrial tour and shall obey the instructions of the faculty members who are accompanying during the industrial tour.

Yours sincerely,

Nishant Ramawat Signature of the student

Contact Phone No: 8395858404

Name of the Father: Hari Prasad Ramawat

(Parents Signature) Hari Prasad

Contact Phone No: 7230062380

Name of the Mother: Neetu Ramawat

Name of the Guardian: _____

Contact Address: A-501, Anukampa byandam, Sodala, Jaipur

Contact Phone No: 8395858404



TOUR BANNER

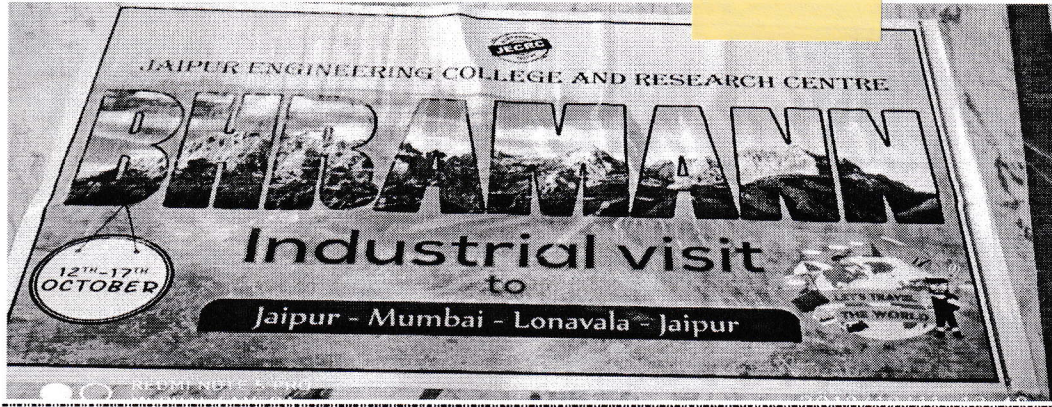

TOUR T-SHIRT





IRCTC's e-Ticketing System
Electronic Reservation Slip (Personal User)



1. You can travel on e-ticket sent on SMS or take a Virtual Reservation Message (VRM) along with any one of the prescribed ID in original. Please do not print the ERS unless extremely necessary. This Ticket will be valid with an ID proof in original. Please carry original identity proof. If found traveling without original ID proof, passenger will be treated as without ticket and charged as per extent Railway Rules.
2. Only confirmed/RAC/Partially confirmed E-ticket is valid for travel. Fully Waitlisted E-ticket is invalid for travel if it remains fully waitlisted after preparation of chart and the refund of the booking amount shall be credited to the account used for payment for booking of the ticket. Travelling on a fully waitlisted e-ticket is illegal.
3. Valid IDs to be presented during train journey by one of the passenger booked on an e-ticket :- Voter Identity Card / Passport / PAN Card / Driving License / Photo ID card issued by Central / State Govt / Public Sector Undertakings of State / Central Government, District Administrations, Municipal bodies and Panchayat Administrations which are having serial number / Student Identity Card with photograph issued by recognized School or College for their students / Nationalized Bank Passbook with photograph / Credit Cards issued by Banks with laminated photograph/Unique Identification Card "Aadhaar".
4. Service Accounting Code (SAC) 996411: Local land transport services of passengers by railways for distance upto 150 Kms Service Accounting Code (SAC) 996416: Sightseeing transportation services by railways for Tourist Ticket Service Accounting Code (SAC) 996421: Long distance transport services of passengers through rail network by Railways for distance beyond 150 KMs
5. General rules/ Information for e-ticket passenger have to be studied by the customer for cancellation & refund.

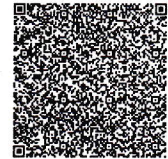

PNR No: 2452179372	Train No. & Name: 12956 / JP MMCT SUPFAST	Quota: GENERAL (GN)
Transaction ID: 100001462541728	Date & Time Of Booking: 30-Sep-2018 17:29:24 HRS	Class: SLEEPER CLASS (SL)
From: JAIPUR(JP)	Date Of Journey: 12-Oct-2018	To: MUMBAI CENTRAL(MMCT)
Boarding At: JAIPUR(JP)	Date Of Boarding: 12-Oct-2018	Scheduled Departure: 12-Oct-2018 14:00 *
From Upto: MUMBAI CENTRAL(MMCT)	Scheduled Arrival: 13-Oct-2018 07:40 *	Adult: 6 Child: 0
Passenger Mobile No: 9694085244		Distance: 1159KM
Passenger Address	15/335, Ajmer, RAJASTHAN - 305001	

FARE DETAILS :

Basic Fare **	3210.0	Rupees three thousand two hundred ten and Zero paisa
IRCTC Service Charge (Incl. of GST)	0.0	Rupees Zero and Zero paisa
Travel Insurance Premium (Incl. of GST)	4.08	Rupees four and eight paisa
Total Fare (all inclusive)	3214.08	Rupees three thousand two hundred fourteen and eight paisa

* Service Charges per e-ticket irrespective of number of passengers on the ticket.

PASSENGER DETAILS :

Sl. No.	Name	Age	Sex	Booking Status	Current Status
1	HARSH	20	Male	CNF/S9/18/MIDDLE	CNF/S9/18/MIDDLE
2	ANMOL	20	Male	CNF/S9/19/UPPER	CNF/S9/19/UPPER
3	JAYESH	21	Male	CNF/S9/21/MIDDLE	CNF/S9/21/MIDDLE
4	HIMANK	20	Male	CNF/S9/22/UPPER	CNF/S9/22/UPPER
5	HIMANK	20	Male	CNF/S9/24/SIDE UPPER	CNF/S9/24/SIDE UPPER
6	KANISHK	18	Male	CNF/S9/56/SIDE UPPER	CNF/S9/56/SIDE UPPER

Indian Railways GST Details :

Invoice Number : PS18245217937211 Address: Indian Railways New Delhi

Supplier Information		Recipient Information		Taxable Value	CGST	SGST/UGST	IGST	Total Tax
GSTIN	GSTIN	Name	Address	Value	Rate	Amount	Rate	Amount

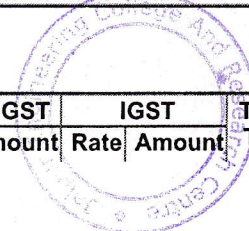



IRCTCs e-Ticketing Service
Electronic Reservation Slip (Personal
User)



1. You can travel on e-ticket sent on SMS or take a Virtual Reservation Message (VRM) along with any one of the prescribed ID in original. Please do not print the ERS unless extremely necessary. This Ticket will be valid with an ID proof in original. Please carry original identity proof. If found traveling without original ID proof, passenger will be treated as without ticket and charged as per extent Railway Rules.

2. Only confirmed/RAC/Partially confirmed E-ticket is valid for travel. Fully Waitlisted E-ticket is invalid for travel if it remains fully waitlisted after preparation of chart and the refund of the booking amount shall be credited to the account used for payment for booking of the ticket. Travelling on a fully waitlisted e-ticket is illegal.

3. Valid IDs to be presented during train journey by one of the passenger booked on an e-ticket :- Voter Identity Card / Passport / PAN Card / Driving License / Photo ID card issued by Central / State Govt / Public Sector Undertakings of State / Central Government, District Administrations, Municipal bodies and Panchayat Administrations which are having serial number / Student Identity Card with photograph issued by recognized School or College for their students / Nationalized Bank Passbook with photograph / Credit Cards issued by Banks with laminated photograph/Unique Identification Card "Aadhaar".

4. Service Accounting Code (SAC) 996411: Local land transport services of passengers by railways for distance upto 150 KMs Service Accounting Code (SAC) 996416: Sightseeing transportation services by railways for Tourist Ticket Service Accounting Code (SAC) 996421: Long distance transport services of passengers through rail network by Railways for distance beyond 150 KMs

5. General rules/ Information for e-ticket passenger have to be studied by the customer for cancellation & refund.



PNR No: 2452179398	Train No. & Name: 12956 / JP MMCT SUPFAST	Quota: GENERAL (GN)
Transaction ID: 100001462541782	Date & Time Of Booking: 30-Sep-2018 17:41:33 HRS	Class: SLEEPER CLASS (SL)
From: JAIPUR(JP)	Date Of Journey: 12-Oct-2018	To: MUMBAI CENTRAL(MMCT)
Boarding At: JAIPUR(JP)	Date Of Boarding: 12-Oct-2018	Scheduled Departure: 12-Oct-2018 14:00 *
Resv. Upto: MUMBAI CENTRAL(MMCT)	Scheduled Arrival: 13-Oct-2018 07:40 *	Adult: 6 Child: 0
Passenger Mobile No: 9694085244		Distance: 1159KM
Passenger Address	15/335, Ajmer, RAJASTHAN - 305001	
N S		

FARE DETAILS :

Ticket Fare **	<input type="checkbox"/> 3210.0	Rupees three thousand two hundred ten and Zero paise
IRCTC Service Charge (Incl. of GST) #	<input type="checkbox"/> 0.0	Rupees Zero and Zero paise
Travel Insurance Premium (Incl. of GST)	<input type="checkbox"/> 4.08	Rupees four and eight paise
Total Fare (all inclusive)	<input type="checkbox"/> 3214.08	Rupees three thousand two hundred fourteen and eight paise

Service Charges per e-ticket irrespective of number of passengers on the ticket.

PASSENGER DETAILS :

SI No.	Name	Age	Sex	Booking Status	Current Status
1	NISHANT	19	Male	CNF/S7/10/MIDDLE	CNF/S7/10/MIDDLE
2	VINAYAK	20	Male	CNF/S7/11/UPPER	CNF/S7/11/UPPER
3	VAIBHAV	20	Male	CNF/S7/13/MIDDLE	CNF/S7/13/MIDDLE
4	RAJ	19	Male	CNF/S7/14/UPPER	CNF/S7/14/UPPER
5	KARTIK	18	Male	CNF/S7/16/SIDE UPPER	CNF/S7/16/SIDE UPPER
6	VISHAL	19	Male	CNF/S7/62/UPPER	CNF/S7/62/UPPER

Indian Railways GST Details :

Invoice Number : PS18245217939811 Address: Indian Railways New Delhi

Supplier Information		Recipient Information		Taxable	CGST		SGST/UGST		IGST		Total	
SAC	GSTIN	GSTIN	Name	Address	Value	Rate	Amount	Rate	Amount	Rate	Amount	Tax



IRCTCs e-Ticketing Service
Electronic Reservation Slip (Personal User)



1. You can travel on e-ticket sent on SMS or take a Virtual Reservation Message (VRM) along with any one of the prescribed ID in original. Please do not print the ERS unless extremely necessary. This Ticket will be valid with an ID proof in original. Please carry original identity proof. If found traveling without original ID proof, passenger will be treated as without ticket and charged as per extent Railway Rules.

2. Only confirmed/RAC/Partially confirmed E-ticket is valid for travel. Fully Waitlisted E-ticket is invalid for travel if it remains fully waitlisted after preparation of chart and the refund of the booking amount shall be credited to the account used for payment for booking of the ticket. Travelling on a fully waitlisted e-ticket is illegal.

3. Valid IDs to be presented during train journey by one of the passenger booked on an e-ticket :- Voter Identity Card / Passport / PAN Card / Driving License / Photo ID card issued by Central / State Govt / Public Sector Undertakings of State / Central Government, District Administrations, Municipal bodies and Panchayat Administrations which are having serial number / Student Identity Card with photograph issued by recognized School or College for their students / Nationalized Bank Passbook with photograph / Credit Cards issued by Banks with laminated photograph / Unique Identification Card "Aadhaar".

4. Service Accounting Code (SAC) 996411: Local land transport services of passengers by railways for distance upto 150 Kms Service Accounting Code (SAC) 996416: Sightseeing transportation services by railways for Tourist Ticket Service Accounting Code (SAC) 996421: Long distance transport services of passengers through rail network by Railways for distance beyond 150 KMs

5. General rules/ Information for e-ticket passenger have to be studied by the customer for cancellation & refund.

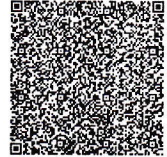

PNR No: 2614295981	Train No. & Name: 12956 / JP MMCT SUPFAST	Quota: GENERAL (GN)
Transaction ID: 100001462541883	Date & Time Of Booking: 30-Sep-2018 18:02:25 HRS	Class: SLEEPER CLASS (SL)
From: JAIPUR(JP)	Date Of Journey: 12-Oct-2018	To: MUMBAI CENTRAL(MMCT)
Boarding At: JAIPUR(JP)	Date Of Boarding: 12-Oct-2018	Scheduled Departure: 12-Oct-2018 14:00 *
Resv. Upto: MUMBAI CENTRAL(MMCT)	Scheduled Arrival: 13-Oct-2018 07:40 *	Adult: 6 Child: 0
Passenger Mobile No: 9694085244		Distance: 1159KM
Passenger Address	plot no. c-1 j.p colony, ~tonk phatak, ~jaipur, JAIPUR, RAJASTHAN - 302015	
N S		

FARE DETAILS :

Ticket Fare **	<input type="checkbox"/> 3210.0	Rupees three thousand two hundred ten and Zero paisa
IRCTC Service Charge (Incl. of GST) #	<input type="checkbox"/> 0.0	Rupees Zero and Zero paisa
Travel Insurance Premium (Incl. of GST)	<input type="checkbox"/> 4.08	Rupees four and eight paisa
Total Fare (all inclusive)	<input type="checkbox"/> 3214.08	Rupees three thousand two hundred fourteen and eight paisa

Service Charges per e-ticket irrespective of number of passengers on the ticket.

PASSENGER DETAILS :

SI No.	Name	Age	Sex	Booking Status	Current Status
1	POOJA	20	Female	CNF/S7/66/MIDDLE	CNF/S7/66/MIDDLE
2	NEHA	20	Female	CNF/S7/67/UPPER	CNF/S7/67/UPPER
3	ISHA	20	Female	CNF/S7/69/MIDDLE	CNF/S7/69/MIDDLE
4	KANIKA	20	Female	CNF/S7/70/UPPER	CNF/S7/70/UPPER
5	USHA	20	Female	CNF/S7/72/SIDE UPPER	CNF/S7/72/SIDE UPPER
6	NIKITA	20	Female	CNF/S7/64/SIDE UPPER	CNF/S7/64/SIDE UPPER

Indian Railways GST Details :

Invoice Number : PS18261429598111 Address: Indian Railways New Delhi

Supplier Information		Recipient Information			Taxable Value	CGST	SGST/UGST	IGST	Total Tax
SAC	GSTIN	GSTIN	Name	Address	Value	Rate	Amount	Rate	Amount

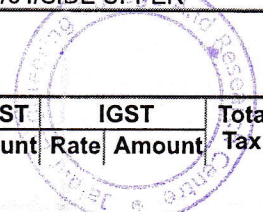



IRCTCs e-Ticketing Service
Electronic Reservation Slip (Personal User)



1. You can travel on e-ticket sent on SMS or take a Virtual Reservation Message (VRM) along with any one of the prescribed ID in original. Please do not print the ERS unless extremely necessary. This Ticket will be valid with an ID proof in original. Please carry original identity proof. If found traveling without original ID proof, passenger will be treated as without ticket and charged as per extent Railway Rules.
2. Only confirmed/RAC/Partially confirmed E-ticket is valid for travel. Fully Waitlisted E-ticket is invalid for travel if it remains fully waitlisted after preparation of chart and the refund of the booking amount shall be credited to the account used for payment for booking of the ticket. Travelling on a fully waitlisted e-ticket is illegal.
3. Valid IDs to be presented during train journey by one of the passenger booked on an e-ticket :- Voter Identity Card / Passport / PAN Card / Driving License / Photo ID card issued by Central / State Govt / Public Sector Undertakings of State / Central Government, District Administrations, Municipal bodies and Panchayat Administrations which are having serial number / Student Identity Card with photograph issued by recognized School or College for their students / Nationalized Bank Passbook with photograph / Credit Cards issued by Banks with laminated photograph/Unique Identification Card "Aadhaar".
4. Service Accounting Code (SAC) 996411: Local land transport services of passengers by railways for distance upto 150 KMs Service Accounting Code (SAC) 996416: Sightseeing transportation services by railways for Tourist Ticket Service Accounting Code (SAC) 996421: Long distance transport services of passengers through rail network by Railways for distance beyond 150 KMs
5. General rules/ Information for e-ticket passenger have to be studied by the customer for cancellation & refund.



PNR No: 2252180686	Train No. & Name: 12956 / JP MMCT SUPFAST	Quota: GENERAL (GN)
Transaction ID: 100001462720017	Date & Time Of Booking: 30-Sep-2018 18:25:42 HRS	Class: SLEEPER CLASS (SL)
From: JAIPUR(JP)	Date Of Journey: 12-Oct-2018	To: MUMBAI CENTRAL(MMCT)
Boarding At: JAIPUR(JP)	Date Of Boarding: 12-Oct-2018	Scheduled Departure: 12-Oct-2018 14:00 *
Resv. Upto: MUMBAI CENTRAL(MMCT)	Scheduled Arrival: 13-Oct-2018 07:40 *	Adult: 6 Child: 0
Passenger Mobile No: 9694085244		Distance: 1159KM
Passenger Address	31,SATYAVATIKA-KARTARPURA-JAIPUR, JAIPUR, RAJASTHAN - 302006	
N S		

FARE DETAILS :

Ticket Fare **	<input type="checkbox"/> 3210.0	Rupees three thousand two hundred ten and Zero paisa
IRCTC Service Charge (Incl. of GST) #	<input type="checkbox"/> 0.0	Rupees Zero and Zero paisa
Travel Insurance Premium (Incl. of GST)	<input type="checkbox"/> 4.08	Rupees four and eight paisa
Total Fare (all inclusive)	<input type="checkbox"/> 3214.08	Rupees three thousand two hundred fourteen and eight paisa

Service Charges per e-ticket irrespective of number of passengers on the ticket.

PASSENGER DETAILS :

Sl No.	Name	Age	Sex	Booking Status	Current Status
1	SHIVANI	19	Female	CNF/S9/5/MIDDLE	CNF/S9/5/MIDDLE
2	TIKSHA	20	Female	CNF/S9/6/UPPER	CNF/S9/6/UPPER
3	HIMANI	21	Female	CNF/S9/8/SIDE UPPER	CNF/S9/8/SIDE UPPER
4	RISHABH	20	Male	CNF/S9/64/SIDE UPPER	CNF/S9/64/SIDE UPPER
5	HIMANSHU	20	Male	CNF/S9/72/SIDE UPPER	CNF/S9/72/SIDE UPPER
6	VAIBHAV	20	Male	CNF/S8/8/SIDE UPPER	CNF/S8/8/SIDE UPPER

Indian Railways GST Details :

Invoice Number : PS18225218068611 Address: Indian Railways New Delhi

Supplier Information		Recipient Information		Taxable Value	CGST		SGST/UGST		IGST		Total Tax
SAC	GSTIN	GSTIN	Name		Address	Rate	Amount	Rate	Amount	Rate	



IRCTCs e-Ticketing Service
Electronic Reservation Slip (Personal
User)



1. You can travel on e-ticket sent on SMS or take a Virtual Reservation Message (VRM) along with any one of the prescribed ID in original. Please do not print the ERS unless extremely necessary. This Ticket will be valid with an ID proof in original. Please carry original identity proof. If found traveling without original ID proof, passenger will be treated as without ticket and charged as per extent Railway Rules.

2. Only confirmed/RAC/Partially confirmed E-ticket is valid for travel. Fully Waitlisted E-ticket is invalid for travel if it remains fully waitlisted after preparation of chart and the refund of the booking amount shall be credited to the account used for payment for booking of the ticket. Travelling on a fully waitlisted e-ticket is illegal.

3. Valid IDs to be presented during train journey by one of the passenger booked on an e-ticket :- Voter Identity Card / Passport / PAN Card / Driving License / Photo ID card issued by Central / State Govt / Public Sector Undertakings of State / Central Government, District Administrations, Municipal bodies and Panchayat Administrations which are having serial number / Student Identity Card with photograph issued by recognized School or College for their students / Nationalized Bank Passbook with photograph / Credit Cards issued by Banks with laminated photograph/Unique Identification Card "Aadhaar".

4. Service Accounting Code (SAC) 996411: Local land transport services of passengers by railways for distance upto 150 KMs Service Accounting Code (SAC) 996416: Sightseeing transportation services by railways for Tourist Ticket Service Accounting Code (SAC) 996421: Long distance transport services of passengers through rail network by Railways for distance beyond 150 KMs

5. General rules/ Information for e-ticket passenger have to be studied by the customer for cancellation & refund.



PNR No: 2252181380	Train No. & Name: 12956 / JP MMCT SUPFAST	Quota: GENERAL (GN)
Transaction ID: 100001462720250	Date & Time Of Booking: 30-Sep-2018 18:55:58 HRS	Class: SLEEPER CLASS (SL)
From: JAIPUR(JP)	Date Of Journey: 12-Oct-2018	To: MUMBAI CENTRAL(MMCT)
Boarding At: JAIPUR(JP)	Date Of Boarding: 12-Oct-2018	Scheduled Departure: 12-Oct-2018 14:00 *
Resv. Upto: MUMBAI CENTRAL(MMCT)	Scheduled Arrival: 13-Oct-2018 07:40 *	Adult: 6 Child: 0
Passenger Mobile No: 9694085244		Distance: 1159KM
Passenger Address	31~satyavatika~kartarpura, Jaipur, Rajasthan - 302006	
N S		

FARE DETAILS :

Ticket Fare **	<input type="checkbox"/> 3210.0	Rupees three thousand two hundred ten and Zero paise
IRCTC Service Charge (Incl. of GST) #	<input type="checkbox"/> 0.0	Rupees Zero and Zero paise
Travel Insurance Premium (Incl. of GST)	<input type="checkbox"/> 4.08	Rupees four and eight paise
Total Fare (all inclusive)	<input type="checkbox"/> 3214.08	Rupees three thousand two hundred fourteen and eight paise

Service Charges per e-ticket irrespective of number of passengers on the ticket.

PASSENGER DETAILS :

Sl No.	Name	Age	Sex	Booking Status	Current Status
1	NAMANDEEP	19	Male	RAC/7	RAC/7
2	UTKARSH	21	Male	RAC/8	RAC/8
3	NISHANT	20	Male	RAC/9	RAC/9
4	SHIVANSH	20	Male	RAC/10	RAC/10
5	SHREYA	19	Female	RAC/11	RAC/11
6	UTSAV	20	Male	RAC/12	RAC/12

Indian Railways GST Details :

Invoice Number : PS18225218138011 Address: Indian Railways New Delhi

Supplier Information		Recipient Information		Taxable Value	CGST		SGST/UGST		IGST		Total Tax
SAC	GSTIN	GSTIN	Name		Address	Rate	Amount	Rate	Amount	Rate	

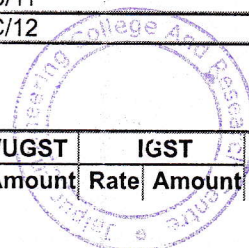

IRCTCs e-Ticketing Service
Electronic Reservation Slip (Personal User)



1. You can travel on e-ticket sent on SMS or take a Virtual Reservation Message (VRM) along with any one of the prescribed ID in original. Please do not print the ERS unless extremely necessary. This Ticket will be valid with an ID proof in original. Please carry original identity proof. If found traveling without original ID proof, passenger will be treated as without ticket and charged as per extent Railway Rules.

2. Only confirmed/RAC/Partially confirmed E-ticket is valid for travel. Fully Waitlisted E-ticket is invalid for travel if it remains fully waitlisted after preparation of chart and the refund of the booking amount shall be credited to the account used for payment for booking of the ticket. Travelling on a fully waitlisted e-ticket is illegal.

3. Valid IDs to be presented during train journey by one of the passenger booked on an e-ticket :- Voter Identity Card / Passport / PAN Card / Driving License / Photo ID card issued by Central / State Govt / Public Sector Undertakings of State / Central Government, District Administrations, Municipal bodies and Panchayat Administrations which are having serial number / Student Identity Card with photograph issued by recognized School or College for their students / Nationalized Bank Passbook with photograph / Credit Cards issued by Banks with laminated photograph / Unique Identification Card "Aadhaar".

4. Service Accounting Code (SAC) 996411: Local land transport services of passengers by railways for distance upto 150 KMs Service Accounting Code (SAC) 996416: Sightseeing transportation services by railways for Tourist Ticket Service Accounting Code (SAC) 996421: Long distance transport services of passengers through rail network by Railways for distance beyond 150 KMs

5. General rules/ Information for e-ticket passenger have to be studied by the customer for cancellation & refund.

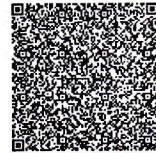

PNR No: 2252182062	Train No. & Name: 12956 / JP MMCT SUPFAST	Quota: GENERAL (GN)
Transaction ID: 100001462720406	Date & Time Of Booking: 30-Sep-2018 19:23:03 HRS	Class: SLEEPER CLASS (SL)
From: JAIPUR(JP)	Date Of Journey: 12-Oct-2018	To: MUMBAI CENTRAL(MMCT)
Boarding At: JAIPUR(JP)	Date Of Boarding: 12-Oct-2018	Scheduled Departure: 12-Oct-2018 14:00 *
Resv. Upto: MUMBAI CENTRAL(MMCT)	Scheduled Arrival: 13-Oct-2018 07:40 *	Adult: 5 Child: 0
Passenger Mobile No: 9694085244		Distance: 1159KM
Passenger Address	1175, Jaipur, RAJASTHAN - 302001	
N S		

FARE DETAILS :

Ticket Fare **	2675.0	Rupees two thousand six hundred seventy five and Zero paise
IRCTC Service Charge (Incl. of GST) #	0.0	Rupees Zero and Zero paise
Travel Insurance Premium (Incl. of GST)	3.4	Rupees three and forty paise
Total Fare (all inclusive)	2678.4	Rupees two thousand six hundred seventy eight and forty paise

Service Charges per e-ticket irrespective of number of passengers on the ticket.

PASSENGER DETAILS :

SI No.	Name	Age	Sex	Booking Status	Current Status
1	RAHUL	26	Male	RAC/13	RAC/13
2	SHAILENDRA	35	Male	RAC/14	RAC/14
3	NEHA	27	Female	RAC/15	RAC/15
4	ANOOP	28	Male	RAC/16	RAC/16
5	ASHISH	30	Male	RAC/17	RAC/17

Indian Railways GST Details :

Invoice Number : PS18225218206211 Address: Indian Railways New Delhi

Supplier Information		Recipient Information			Taxable Value	CGST		SGST/UGST		IGST		Total Tax
SAC Code	GSTIN	GSTIN	Name	Address		Rate	Amount	Rate	Amount	Rate	Amount	

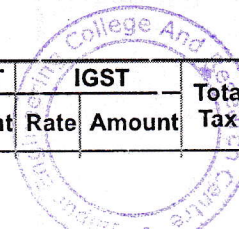



JAIPUR ENGINEERING COLLEGE
AND RESEARCH CENTRE

Ref: JECRC/2018-19/103

Date: 02/10/18

To

The Associate Director
BTDG
BARC, Mumbai.

SUB: Permission for Industrial Visit – B.Tech Students

Sir/Madam,

As you may be aware, Jaipur Engineering College & Research Centre, Jaipur is one of the most reputed engineering institutions in Rajasthan and known for its excellent record in academics and co-curricular activities. The college offers bachelors degree course in ECE, EE, CSE, IT, ME and Civil branches. The state-of-art facilities and competent faculty provide an excellent climate for the all-round development of students.

As a part of the curriculum, the students are required to undertake industrial visits to few industries of repute. It will be fruitful for the students with academic background to have a glimpse of the industry in order to have a better knowledge of practical applications of theory. In the above background we would like to send a batch of about 56 students of Electrical Engineering and Computer science Engineering Branch of 2nd and 3rd year accompanied by 5 faculty members to visit your esteemed industry preferably on 15th October 2018.

We kindly request you to accord the necessary permission for the above visit and arrange for guiding the students. We assure you that our students will follow the rules and regulations that are prescribed by your company for the visitors and will in no way disturb the functioning of the company during their visit. We shall be grateful for a favorable response.

Thanking You,

Yours faithfully,

Dr. V.K. Chandna
Principal

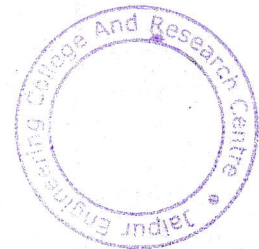

Room Allotment

Hotel UNITED 21 Retreat, Lonavala

S. NO	Room No	Student Serial no
1	430	1,2,5,4
2	415	3,6,11,13
3	418	7,8,45,38
4	414	10,14,15,16
5	428	12,18,21,22
6	431	46,19,51,54
7	425	53,54,47,48
8	419	9,17,19,20
9	424	31,32,34,35
10	420	56,55,33, Neha Mam
11	421	24,25,29,30
12	423	26,27,28,23
13	417	36,37,40,39
14	416	41,12,13,44
15	101	Shailendra, Rahul
16	103	Ashish, Anoop



Hotel JUHU Plaza, Bombay

S. NO	Room No	Student Serial no
1	201	1,2,5,4
2	202	3,6,11,13
3	203	7,8,45,38
4	204	10,14,15,16
5	205	12,18,21,22
6	208	46,19,51,54
7	207	53,54,47,48
8	206	9,17,19,20
9	501	31,32,34,35
10	502	56,55,33, Neha Mam
11	503	24,25,29,30
12	505	26,27,28,23
13	504	36,37,40,39
14	506	41,12,13,44
15	508	Shailendra, Rahul
16	507	Ashish, Anoop





BHRAMANN BHRAMANN <bhramann@jecrc.ac.in>

Tour Billing

1 message

Travel 1 2 Go <travel12go@gmail.com>
To: BHRAMANN BHRAMANN <bhramann@jecrc.ac.in>

Tue, Nov 13, 2018 at 11:04 AM

Dear Sir
Greeting of the day..!!

We Have received Full Payment (56*7800)= 436800/-Rs Against Industrial tour of Mumbai Lonavala.

Thanks for Bhramann Team for Cooperation & Support..!!

Thanks
Sachin Sharma
9772577729

Travel 1 2 Go
31, Satya Vatika , Kartarpura ,
Jaipur, Rajasthan - 302006
Tel.: +91 -141-2500466 |
Mobile : 9829823456 | 9928555583 | 9772577729 | 8104012003 | 9694085244
website -www.travel12go.com/in , www.educationtourindia.com
Mail.- travel12go@gmail.com , info@travel12go.com
<https://www.facebook.com/Travel-1-2-Go-Educational-Tours-229171723792360/>

Please do not print this e-mail unless it is absolutely necessary



Bhramann: Travel to Conquer Space and Time

REPORT
On
INDUSTRIAL TOUR

OCTOBER 12, 2018 – OCTOBER 17, 2018

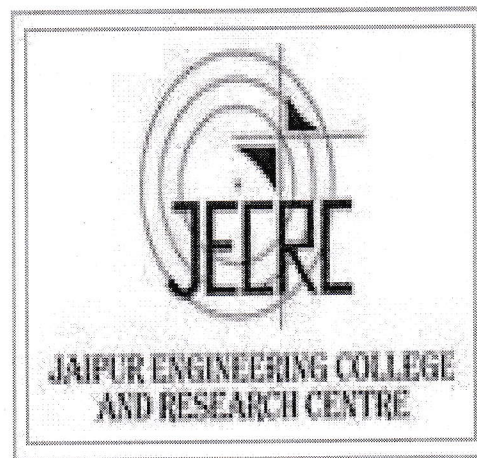

JAIPUR ENGINEERING COLLEGE & RESEARCH CENTRE

Organised by:

Department of Electrical Engineering

JECRC, Jaipur



TOUR - MAP

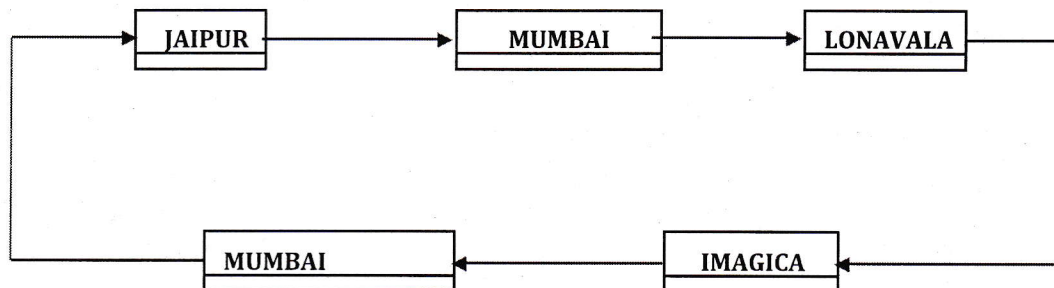

TOUR-AGENCY : TRAVEL 1 2 GO

FACULTY- COORDINATORS	Mr. SHAIENDRA SRIVASTAVA (EE) Mr. RAHUL KUMAR MALEE (EE) Ms. NEHA AGRAWAL EE) Mr. ANOOP KUMAR MEHTA (CS) Mr. ASHISH SHARMA (Bhramann)
TOTAL NUMBER OF STUDENTS	56
ELECTRICAL ENGINEERING	45
COMPUTER SCIENCE	11
BOYS STUDENTS	41
GIRLS STUDENTS	15

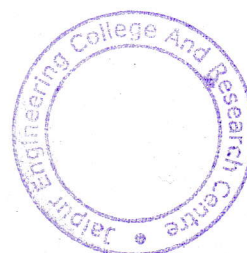

TOUR ITINERARY

Jaipur- Mumbai -Lonavala With Adlabs Imagica Water Park

- 1. Duration** 5Nights / 6Days
Mumbai -Lonavala with Imagica water
- 2. Destination:** Park
- 3. Cost Per head** 7800/- Per Student

Day 1. 12 Oct 2018 Jaipur -Mumbai

Arrive at Jaipur Railway Station At 1 PM, Board In Train at (2 Pm JpBct Sup.) & O/n Journey for Mumbai (Dinner)

Day2. 13 Oct 2018 Mumbai --Lonavala

Arrive Mumbai railway station 7.30 Am, Board in bus & Proceed for Lonavala on arrival check inn hotel after lunch enjoy sightseeing like- Tiger leap , Bushy dam, lonavala lake , Curla caves, Sunset point etc evening back to hotel after dinner o/n stay at hotel. (Breakfast/Lunch/Dinner)

Day 3. 14 Oct 2018 Lonavala-Imagica Water Park-Lonavala

Morning after breakfast Proceed for Visit Imagica Water Park enjoy world Famous Water Rides here evening back to hotel after dinner o/n stay at hotel.. (Breakfast/Lunch/Dinner)

Day 4. 15 Oct 2018 lonavala- Mumbai

Morning after breakfast check out from hotel & proceed for Industrial Visit after this Check inn hotel after lunch enjoy sightseeing of Mumbai like- Gateway of India, Nariman Point, Mahalaxmi Temple, Hazi Ali, Juhu Chaupati etc evening back to hotel after dinner o/n stay at hotel. (Breakfast/Lunch/Dinner)

Day 5. 16 Oct 2018 Mumbai - Jaipur

Morning after breakfast checkout from hotel & enjoy shopping & remaining sightseeing after this proceed for Mumbai Railway station board in train (6.50 Pm Mmct Jp Sup Exp) & o/n journey for Jaipur. (Breakfast/Lunch/Dinner)

Day 6. 17 Oct 2018 Jaipur

Reach Jaipur Railway Station at 12.45 Pm. (Breakfast)



Industries

BARC(Electron Beam Centre), Belapur, New

Mumbai Inclusion

1. Accommodation at 4 sharing In 3 star
2. Transport (Non AC)
3. All major Sightseeing
4. Return train tickets (sl class)
5. Entry ticket of Imagica water park
6. Train meal
7. Morning Tea- Coffee
8. Travel Insurance till 1 lakh
9. 1Dj Party
10. Water Bottle 1 Per Day
11. Buffet Breakfast, lunch & dinner at hotel
12. First Aid Kit
13. All monument Entry
14. Teacher comp 15:1
15. Toll Tax, Parking ,Driver Allowance

Exclusion

1. 5 % Gst
2. Any porter charges
3. Any personal nature expenditure
4. Anything not mentioned under cost included items
5. Any uses in the hotel like telephone, laundry personal order etc.
6. Any damage/destroy in the hotel room by clients, will be directly chargeable to clients
7. Mineral water
8. Horse riding / Water Sports

Payment terms:

1. 50% of the complete package amount (pertaining to the minimum guarantee of student count) at the time of booking of the package;
2. 40% of the rest amount to be paid 15 days before the date of departure
3. 10% of the rest amount to be paid within 7 days of completion of tour.

Cancellation Charges/Policy:

1. Cancellation before 15 days before departure date a cancellation charge of 25% of the total tour package amount.
2. Cancellation before 3 days and up to 15 days before departure date a cancellation charge of 50% of the total package amount.
3. No show or cancellation up to 3 days before departure date a cancellation charge of 100% of the total package amount.

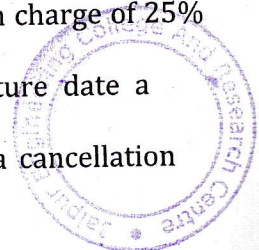

TERMS AND CONDITIONS:

1. Rates mentioned in this contract are applicable only for this Conference/Leisure Trip/Offsite/Training Program/Event to be held on the date mentioned in this proposal.
2. Early check-in and late check-out will be charged additionally as per subject to the hotel policies.
3. If there be any reduction in the minimum guaranteed number of pax, Travel12go. Travel12go will charge on the minimum guaranteed number of pax as per the contract and if the number of pax increases, then the billing will be done on the actual number of pax.
4. We would require the signed copy of the contract along with advance payment on the day of signing this contract.
5. We would require the request for additional services if there any, in writing before 10 days from the departure date of Conference/Leisure Trip/Offsite/Training Program/Event and it will be charged extra.
6. All Government policies/regulations prevalent during the time of signing the contract will apply. Travel12go will not be held responsible for any subsequent changes in the government policies, rules and/or regulations. Although no effort will be spared to provide the requested services, travel12go only as agent for Transportation Companies, Hotels, Car operators, Raft operators, DJs,
7. Travel12go reserves the right without being liable for any loss or damage, to change the itinerary with or without notice and at its sole discretion, if found to be in the best interest of all concerned.
8. All disputes will be settled subject to the jurisdiction of rajasthan Courts as per the Laws Prevalent in India at the time of signing the contract.
9. Stage makers, dancer, celebrities and all other contractors, and will therefore have to disclaim responsibility for:
 - i. Any loss, damage or miss-happening what so ever to any person, luggage or property during the entire journey or at the place of stay or during sightseeing or any adventure or other activity.
 - ii. Delay or alteration in programs or expenses due to unforeseen circumstances.
 - iii. Strikes, vehicle breakdown, sickness, or civil unrest and other problems beyond the control of the company

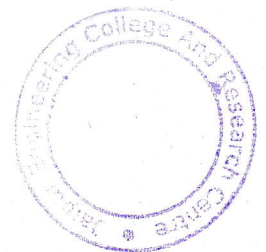

TOUR BANNER



TOUR T-SHIRT



TOUR-DETAIL

Day 1 (12.10.2018)

Assembled at Gate No. 2, Railway Station Jaipur, Main Junction at 01:00 p.m.
Moved to Platform No. 2 with all 56 students and 5 faculties
Train departed for Mumbai at 02:00 p.m.
Train arrived Mumbai Station at 07:30 a.m.
Way to Lonavala by Bus (Via Mumbai)

Day 2 (13.10.2018)

Checked-in hotel United 21 Retreat in Lonavala at 11:00 a.m
Had lunch at 01:00 p.m
Departure from hotel for various sightseeing of Lonavala.
Students enjoyed all the sightseeing and back to hotel.

Day 3 (14.10.2018)

Had breakfast at 8:30 A.M. in hotel.
Departure from hotel for tiger leap, Lonavalalake, Bhushi dam at 09:00 A.M.
Departure from hotel for Imagica snow and water park.
Students enjoyed various water slides and snow park.
Had lunch at Imagica at 03:00 p.m.
Return to hotel at 08:30 p.m.
DJ night was arranged from 09:00 p.m to 10:30 P.M. followed by dinner

Day 4 (15.10.2018)

Had breakfast at 7:30 A.M.

Checked out from hotel and departure for industry visit.
Visit the BARC industry.
Viewed celebrities house on the way to Bandra.
Checked into Hotel Juhu Plaza at Juhu, Mumbai.
Reached Hotel and had lunch at 04:00 p.m
Depart for Juhu beach and Juhuchowpati thereafter at 06:00 P.M.
Had delicious dinner at 09:30 p.m at hotel

Day 5 (16.10.2018)

Had breakfast at 08:00 a.m in hotel.
Checked-out from Hotel Juhu Plaza at 8.30 am.
Enjoyed various sightseeings of Mumbai like Siddhivinayak temple, Hazialidargah, Gateway of India.
Done shopping at Fashion Street, Mumbai.
Had lunch at 03:00 p.m.
Depart for station.
Depart for Jaipur at 06:50 p.m from Mumbai Central

Day 6 (17.10.2018)

Reached Jaipur-Junction at 12:55 P.M.



INDUSTRY VISITS

1. BHABHA ATOMIC RESEARCH CENTRE

Address: Electron Beam Centre, Raintree Marg, Sector 7, CBD Belapur, Navi Mumbai, Maharashtra 410210

Overview:

The **Bhabha Atomic Research Centre (BARC)** is India's premier nuclear research facility headquarter in Trombay, Mumbai, Maharashtra. BARC is a multi-disciplinary research centre with extensive infrastructure for advanced research and development covering the entire spectrum of nuclear science, engineering and related areas.

BARC's core mandate is to sustain peaceful applications of nuclear energy, primarily for power generation. It manages all facts of nuclear power generation, from theoretical design of reactors to, computerised modelling and simulation, risk analysis, development and testing of new reactor fuel materials, etc. It also conducts research in spent fuel processing, and safe disposal of nuclear waste. Its other research focus areas are applications for isotopes in industries, medicine, agriculture, etc. BARC operates a number of research reactors across the country.

The JECRC, students are visited the Electron Beam Centre, Raintree Marg, Sector 7, CBD Belapur, Navi Mumbai, Maharashtra 410210. The students attend the seminar first and then visit the research centre under the guidance of Mr. R. Israel Bakhtsinghscitefic Officer - Head DC Accelerator section APPD BARC. The students are physically seen the designing of HVDC generator of 3 MeV and 10 MeV. The main application of this generator for water treatment of Ganga River cleaning project.



Visit Pictures



Visit Pictures



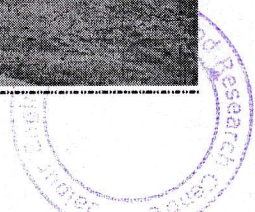

REMINISCENCES



STUDENT AT HOTEL UNITED 21 RETREAT AT LONAVALA



ENJOYING LUNCH AT HOTEL AT LONAVALA





Students at Kalra Caves, Lonavala



STUDENTS AT IMAGICA

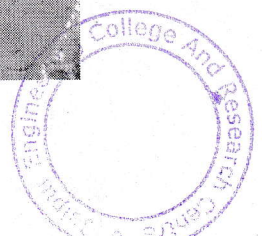



STUDENTS AT IMAGICA WAVE POOL



STUDENTS ENJOYING AT IMAGICA WATER PARK





STUDENTS AT IMAGICA CAFE



DEPARTURE FOR INDUSTRIAL VISIT





ENJOYING AT BUS

We are pleased to share that JECRC Campus successfully organized a Industrial Visit from 12.10.2018 to 17 10.2018. It was an efficient team effort which resulted into a great success. All the students are highly motivated and enthusiastic for Industrial Visit.

This successful Industrial Visit was organized because of the inspiration and motivation of honorable Directors Sh.Amit Agrawal Sir and Sh. Arpit Agrawal Sir. We are very grateful to Dr. V. K. Chandna Sir, Principal, JECRC, Jaipur for guiding us as a light and motivated as a positive leader.

We are thankful to all the dedicated faculty and staff members, devoted team of hardworking students of the institute. We will keep trying our best with the kind cooperation of all of you. Again, our thanks to all involved for their support and participation.



BHRAMANN: Travel to Conquer Space and Time

REPORT

On

INDUSTRIAL TOUR

October 12, 2018 – October 17, 2018

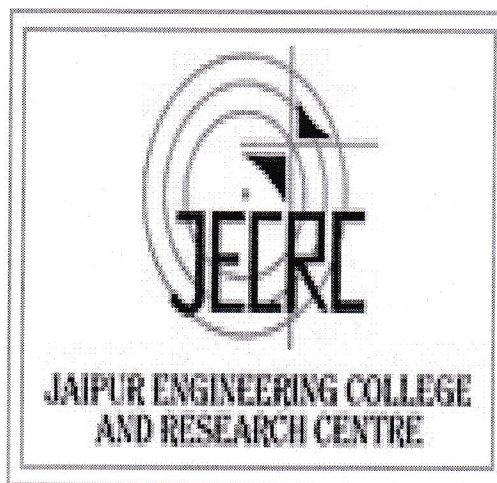

JAIPUR ENGINEERING COLLEGE & RESEARCH CENTRE

Organised by:

Department of Computer Science Engineering

JECRC, Jaipur



TOUR – MAP

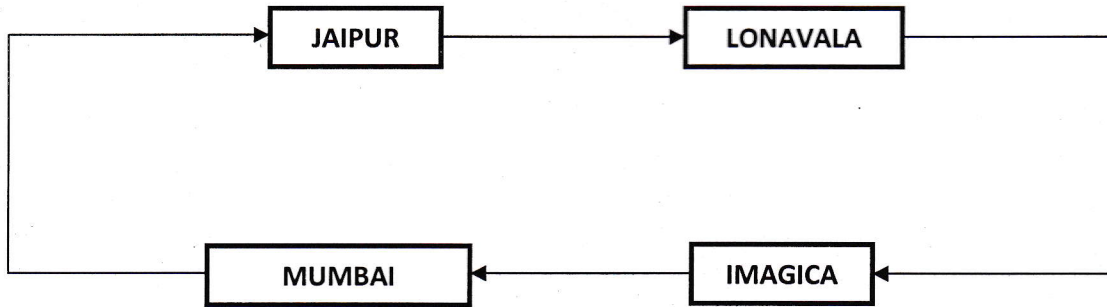

TOUR – PLAN

Day 1 (October 12, 2018): Departure from Jaipur to Mumbai by Train (Overnight Journey).

Day 2 (October 13, 2018): Mumbai to Lonavala by Bus, Lonavala sight-seen and stay at United 21 Resort in Lonavala.

Day 3 (October 14, 2018): Imagica Water Park, DJ Night, Stay at Resort.

Day 4 (October 15, 2018): Lonavala to Mumbai by Bus, Industry Visit, Check-in into Juhu Plaza Hotel.

Day 5 (October 16, 2018): Mumbai sight-seen plus Market, in evening departure from Mumbai to Jaipur (Overnight Journey).

Day 6 (October 17, 2018): Reach Jaipur in the afternoon.

FACULTY- COORDINATORS

1. Mr. Ashish Sharma
2. Mr. Shailendra Srivastava
3. Mr. Rahul Kumar Malee
4. Mr. Anoop Kumar Mehta
5. Ms. Neha

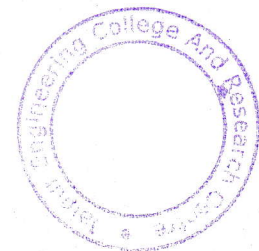

TOUR-AGENCY

Travel12Go

STUDENTS

Total Number: 56

Department wise:

CS (11)

EE (45)

Gender wise:

Girls (15)

Boys (41)

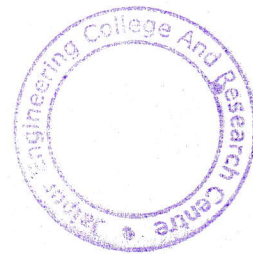

TOUR ITINERARY

Jaipur- Mumbai -Lonavala With Adlabs Imagica Water Park

- 1. Duration:** 5Nights / 6Days
- 2. Destination:** Mumbai –Lonavala with Imagica water Park
- 3. Cost Per head:** 7800/- Per Student

Day 1. 12 Oct 2018 Jaipur –Mumbai

Arrive at Jaipur Railway Station At 1 PM, Board In Train at (2 Pm Jp Bct Sup.) & O/n Journey for Mumbai (Dinner)

Day2. 13 Oct 2018 Mumbai –Lonavala

Arrive Mumbai railway station 7.30 Am, Board in bus & Proceed for Lonavala on arrival check inn hotel after lunch enjoy sightseeing like- Tiger leap , Bushy dam, lonavala lake , Curla caves, Sunset point etc evening back to hotel after dinner o/n stay at hotel. (Breakfast/Lunch/Dinner)

Day 3. 14 Oct 2018 Lonavala-Imagica Water Park-Lonavala

Morning after breakfast Proceed for Visit Imagica Water Park enjoy world Famous Water Rides here evening back to hotel after dinner o/n stay at hotel.. (Breakfast/Lunch/Dinner)

Day 4. 15 Oct 2018 lonavala- Mumbai

Morning after breakfast check out from hotel & proceed for Industrial Visit after this Check inn hotel after lunch enjoy sightseeing of Mumbai like- Gateway of India, Nariman Point, Mahalaxmi Temple, Hazi Ali, Juhu Chaupati etc evening back to hotel after dinner o/n stay at hotel. (Breakfast/Lunch/Dinner)

Day 5. 16 Oct 2018 Mumbai - Jaipur

Morning after breakfast checkout from hotel & enjoy shopping & remaining sightseeing after this proceed for Mumbai Railway station board in train (6.50 Pm Mmct Jp Sup Exp) & o/n journey for Jaipur. (Breakfast/Lunch/Dinner)

Day 6. 17 Oct 2018 Jaipur

Reach Jaipur Railway Station at 12.45 Pm. (Breakfast)

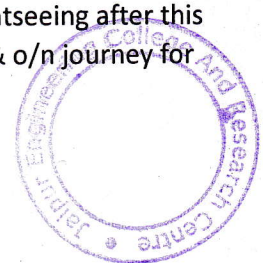

Industry

- BARC

Inclusion

1. Accommodation at 4 sharing In 3 star
2. Transport (Non AC)
3. All major Sightseeing
4. Return train tickets (sl class)
5. Entry ticket of Imagica water park
6. Train meal
7. Morning Tea- Coffee
8. Travel Insurance till 1 lakh
9. 1Dj Party
10. Water Bottle 1 Per Day
11. Buffet Breakfast, lunch & dinner at hotel
12. First Aid Kit
13. All monument Entry
14. Teacher comp 15:1
15. Toll Tax, Parking ,Driver Allowance

Exclusion

1. 5 % Gst
2. Any porter charges
3. Any personal nature expenditure
4. Anything not mentioned under cost included items
5. Any uses in the hotel like telephone, laundry personal order etc.
6. Any damage/destroy in the hotel room by clients, will be directly chargeable to clients
7. Mineral water
8. Horse riding / Water Sports

Payment terms:

1. 50% of the complete package amount (pertaining to the minimum guarantee of student count) at the time of booking of the package;
2. 40% of the rest amount to be paid 15 days before the date of departure
3. 10% of the rest amount to be paid within 7 days of completion of tour.



TOUR-DETAIL

Day 1 (12.10.2018)

- Assembled at Gate No. 1, Railway Station Jaipur, Main Junction at 12:00 P.M.
- Moved to Platform No. 3 with all 56 students and 5 faculties
- Train departed for Mumbai at 2:00 P.M.

Day 2 (13.10.2018)

- Train arrived Mumbai Central Station at 7:30 A.M.
- Way to Lonavala by Bus
- Checked-in United 21 Resort in Lonavala at 11:00 A.M.
- Had Lunch and then move to sightseeing of Lonavala.
- Had dinner at 10:00 P.M.

Day 3 (14.10.2018)

- Had breakfast at 7:30 A.M. and departed for Imagica Water Park.
- Full day enjoy in Water Park.
- DJ night was arranged from 7:00 P.M. to 10:00 P.M. followed by dinner.

Day 4 (15.10.2018)

- Had breakfast at 7:30 A.M. and departed for Mumbai.
- First visit **Electron Beam Centre of BARC** in Mumbai.
- Checked-in Hotel Juhu Plaza in Mumbai at 4:00 P.M.
- Enjoyed at Juhu Beach in evening.
- Had dinner at 10:00 P.M.

Day 5 (16.10.2018)

- Had breakfast at 7:30 A.M.
- Departure from hotel for Mumbai sight-seen i.e. Gateway of India, Siddhi Vinayak, Mahalaxmi Temple, Hazi Ali, Varli Sea Link
- Enjoyed the rest of hours in shopping
- Depart for Mumbai Central Railway Station
- Train departed for Jaipur at 6:50 P.M.

Day 6 (17.10.2018)

- Reached Jaipur-Junction at 12:45 P.M.



INDUSTRY VISITS

1. BARC: BHABHA ATOMIC RESEARCH CENTRE

Address: Central Complex, BARC, Trombay Mumbai 400085 (India)

Overview: The **Bhabha Atomic Research Centre (BARC)** is India's premier nuclear research facility headquartered in Trombay, Mumbai, Maharashtra. BARC is a multi-disciplinary research centre with extensive infrastructure for advanced research and development covering the entire spectrum of nuclear science, engineering and related areas.

BARC's core mandate is to sustain peaceful applications of nuclear energy, primarily for power generation. It manages all facts of nuclear power generation, from theoretical design of reactors to, computerised modelling and simulation, risk analysis, development and testing of new reactor fuel materials, etc. It also conducts research in spent fuel processing, and safe disposal of nuclear waste. Its other research focus areas are applications for isotopes in industries, medicine, agriculture, etc. BARC operates a number of research reactors across the country.

Electron Beam Centre (EBC):

Electron Beam Centre, being established at Kharghar, Navi Mumbai, will house two electron accelerators namely a 3 MeV/30 kW and a 10 MeV/10 kW. At present the accelerator components are being assembled & tested at EBC. At present the accelerator components are being assembled & tested at EBC.



A view of the Electron Beam Centre (EBC) Building



Electron Beam Accelerators

Development of technology and its translation into the setting up of Electron Beam Accelerators are entrusted with APPD. Depending upon the applications, beams of different power and energy are required. Curing of adhesives and paint coatings, radiation induced polymerization and increased cross linking to improve the thermal and mechanical properties of materials, sterilization of medical products, improved colour and acceptability of gems and stones, food preservation etc are some of the newly emerging applications of EB accelerators.

10MeV, 10kW, RF Linac

It is a coupled cavity linac, capable of giving 10 MeV beam with a power of 10 kW. The 50 keV electron beam from the gun is accelerated to 10 MeV in the linac cavity having a length of about 1 m. After the energy analysis, the beam is passed to the scan horn through the sweep scanner.

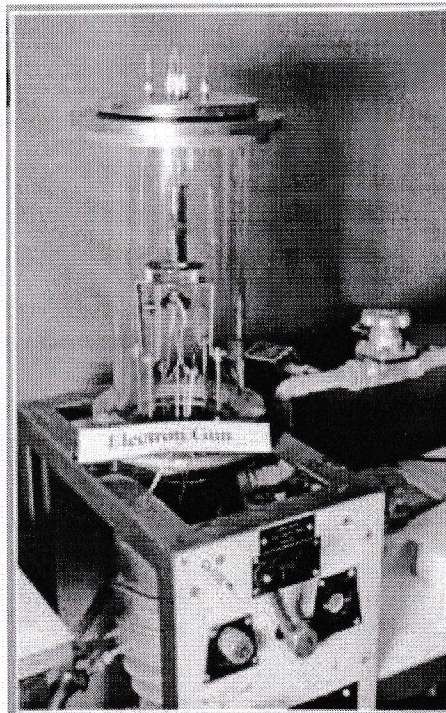
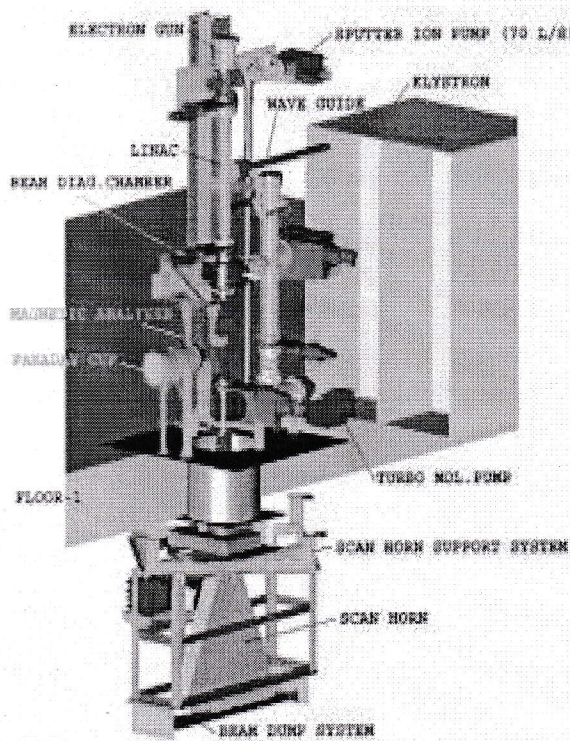

A 3D view of the 10 MeV, 10 kW RF Electron Accelerator Electron Gun for 10 MeV Linac

3MeV, 30kW, DC Accelerator

This accelerator is designed to deliver 30 kW of beam at an energy of 3 MeV. The 5 keV beam from the electron gun is accelerated to 3 MeV in the acceleration tube. The beam, after passing through the scan magnet chamber is let out in the air through the scan horn and is used for processing of the materials. The 45 kW, 120 kHz, 300 kV Oscillator, is being



designed and built for the first time in the country. The corona guard, RF electrodes and HV dome which will handle such large power, are being developed for the first time. Since these products require a good amount of sophistication and do not fall in the conventional manufacture line, the Indian industry had to be educated about each and every aspect of these accelerators. They had to go through a lot of jigs & fixtures and experimentation to acquire the require degree of confidence. At present almost all its subsystems are in the advanced stage of fabrication.



High Voltage Dome for 3 MeV Accelerator

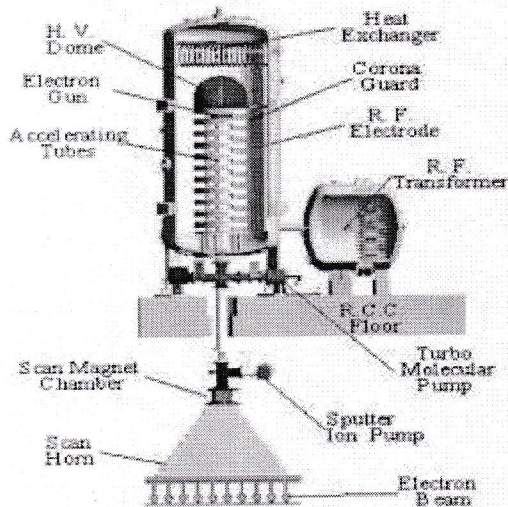

Schematic of 3 MeV, DC Accelerator

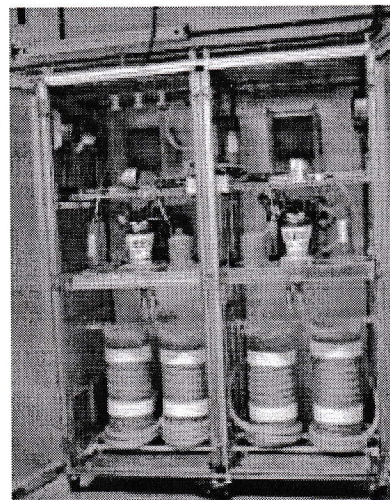

Internal View of the 150 – 0 - 150 kV, 120 kHz RF Oscillator for 3 MeV



Visit Picture:



REMINISCENCES



Students During Enroute



Dinner at Hotel Juhu Plaza





Students at Imagica



Students at Karla Caves Lonavala





Students at Juhu Beach Mumbai

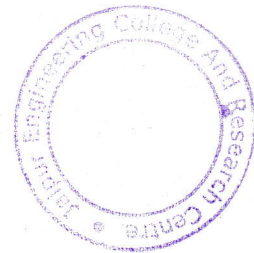

Mail

BHRAMANN BHRAMANN <bhramann@jecrc.ac.in>

Feedback of Industrial Visit

Anoop Kumar Mehta <anoopkumar.cse@jecrc.ac.in>
BHRAMANN BHRAMANN <bhramann@jecrc.ac.in>

Tue, Oct 23, 2018 at 7:17 PM

Dear Sir/Mam,

According to plan of industrial visit from 12/10/18 to 17/10/18, we visited Lonavala, Imagica and Mumbai with 56 students (45 from EE & 11 from CSE).

Overall trip was awesome, all students are happy but in every plan there is some Pro's and Con's.

Pro's:

1. Hotel & Resort facility was very good.
2. Menu & food quality in hotels also good.
2. All destination was covered according to plan.
3. Behavior of tour guide with faculty members and students was very good.

Con's:

1. Breakfast on 13th October & Lunch on 16th October was not up to the mark, which was planned in packed food.
2. When we reach lonavala, hotel rooms was not free, students waited around 30-45 minutes for room allotment.

Regards

Anoop Mehta

Feedback Form

Student's feedback of Industrial Visit:

Select Semester:

- Semester 1
- Semester 2
- Semester 3
- Semester 4
- Semester 5
- Semester 6

Subject area of the Industrial Visit:

Electrical

Was the Industrial Visit helpful to you?

- Yes
- No

Give overall rating to Industrial Visit.

- Excellent
- Very Good
- Good
- Average
- Poor

Do you advise to arrange this type of visit in future?

- Yes
- No

Give your comments on visit

Excellent trip. Please let us go again!!



Feedback Form

Student's feedback of Industrial Visit:

Select Semester:

- Semester 1
- Semester 2
- Semester 3
- Semester 4
- Semester 5
- Semester 6

Subject area of the Industrial Visit:

Electrical

Was the Industrial Visit helpful to you?

- Yes
- No

Give overall rating to Industrial Visit.

- Excellent
- Very Good
- Good
- Average
- Poor

Do you advise to arrange this type of visit in future?

- Yes
- No

Give your comments on visit

Amazing trip



Divyansh Sharma

Feedback Form

Student's feedback of Industrial Visit:

Select Semester:

- Semester 1
- Semester 2
- Semester 3
- Semester 4
- Semester 5
- Semester 6

Subject area of the Industrial Visit:

Electrical

Was the Industrial Visit helpful to you?

- Yes
- No

Give overall rating to Industrial Visit.

- Excellent
- Very Good
- Good
- Average
- Poor

Do you advise to arrange this type of visit in future?

- Yes
- No



Give your comments on visit

Excellent